

# Novel Auction Models and Protocols for Grid Resource Allocation

**Qi-De Lin**

College of Engineering, National Chung Cheng University, Chia-Yi County 621, Taiwan (R.O.C.)

**E-mail:** [qidefor040@yahoo.com.tw](mailto:qidefor040@yahoo.com.tw)

## Abstract

In this paper we propose the double auction allocation models for computational grids, and two double auction protocols for resource allocation: Single Price Double Auction protocol (SPDA), and Multiple Attribute Double Auction protocol (MADA). The fairness and comprehensive performance are introduced into the double auction models to evaluate impact of price, speed and storage of grid resource. The results show that MADA protocol is better from both resource's and user's perspective providing high resource utilization. The results also highlight how a resource user can improve his performance using multi-attribute characteristics.

**Keywords:** grid resource; double auction; satisfaction degree; multi-attribute.

## 1. Introduction

Grid resource computing system is defined as the next generation computing platform to solve large scale problems in science, industry and engineering. Computational grids support the creation of virtual organizations which enable the sharing, exchange, selection, and aggregation of geographically distributed heterogeneous resources [1]. In recent years, business models or economic mechanisms have been proved to be suitable for solving the problem of grid resource allocation [2]. Research on computational grid management can be divided into two categories: commodity market models and auction based models. It has been proved that the auction models are more suitable than commodity market models for the grid resource allocation for its advantages of needing little information, with decentralized structure and more easily to implement [3].

Among the traditional auction models and mechanisms, the double auction has a high potential for grid computing [4]. In a double auction model, consumers submit bids and providers submit requests at any time during the trading period. If at any time there are bids and requests that match or are compatible with a price, then a trade is executed immediately. Suri and Singh [5] presented a modified continuous double auction protocol and gave some results that modified protocol was significantly better than the traditional CDA in terms of reduction in price volatility. Li et al. [6] studied the combinatorial double auction, and designed a novel pricing algorithm for the allocation model to obtain the detailed resource allocation status and the price information. Xia et al. [7] presented that the combinatorial double auction not only had the advantages of the combinatorial auction, but also considered the requirements of both buyers and sellers. Fang et al. [8] established a double auction based Bayesian game with power supplier and demander in open bilateral electricity market, solved the Bayesian Nash equilibrium and gave the equilibrium bidding strategies for power supplier and demander. Prodan et al. [9] designed a novel double auction mechanism which was appropriate for allocation of multi-unit homogenous and divisible resources in the Grid. Kant and Grosu [10] proposed the double auction allocation model for grids, and three double auction protocols

for resource allocation were provided. Wang et al. [11] presented an improved grid resource management model based on double auction and proposed bidding strategies to resolve the low efficiency problem. The simulation results showed that the price strategy could improve the efficiency of grid resource auction.

Different from the original literature, in this paper, the multi-attribute characteristics of computational grid are introduced into the double auction model. In reality, the computer system, network subsystem, file system and database system compose many different resources types. Each resource type has one or more attributes with specific values, such as price, computational speed, storages. Therefore, the attributes of price, speed and storage may influence the auctioneer's decision, simultaneously. In our approach, we design Single Price Double Auction protocol (SPDA), and Multiple Attribute Double Auction protocol (MADA). The simulating experiments show that MADA protocol has good behavior in grid environment. It has better performance on user satisfaction level and market information efficiency.

## 2. Problem formulation

There are three participants in our grid environment. In the following part, we present each of these participants and describe their roles in the protocols and their characteristics in Fig.1.

**Grid Resource Broker (GRB):** GRB acts on behalf of the resource user, i.e., the buyer. The job of GRB is to announce the basic attributes, the required quantities and the asking price of the grid resource. In our model, we assume that each grid resource buyer  $i$  has one independent computational intensive job  $J_i^{(b)}$  for execution and is willing to pay for it. The  $J_i^{(b)}$  is denoted by a four-tuple  $J_i^{(b)} = (L_i^{(b)}, T_i^{(b)}, RP_i^{(b)}, S_i^{(b)})$ , where  $L_i^{(b)}$  is the length of the job of the  $i^{\text{th}}$  resource buyer and is specified by millions of instructions (MI),  $T_i^{(b)}$  determines the job deadline,  $RP_i^{(b)}$  represents the budget allocated to  $J_i^{(b)}$  and  $S_i^{(b)}$  is the minimum storage. Each buyer aims at executing its job within its corresponding deadlines and minimizing the cost. During the auction period, each GRB  $i$  also present request denoted by a two-tuple  $(a_i^{(b)}, q_i^{(b)})$ , where  $a_i^{(b)}$  is the asking price and  $q_i^{(b)}$  is the required quantity.

**Grid Service Provider (GSP):** GSP acts on behalf of the resource provider, i.e., the seller. The job of GSP is to compute the availability of the current resource, estimate the storage capacity and calculate the bidding price of grid resource. In the double auction mechanisms, firstly GRB notifies the specific attribute requirements of computational grid resource. GSP arrives dynamically with his supply ability, accept task and submit his bid. Suppose that GSP  $j$ 's multi-attribute bid  $B_j^{(s)}$  is denoted by  $B_j^{(s)} = (bid_j^{(s)}, q_j^{(s)}, v_j^{(s)}, s_j^{(s)})$ , where  $bid_j^{(s)}$  is the bidding price of the  $j^{\text{th}}$  GSP,  $q_j^{(s)}$  denotes the supply quantity of grid resource by the  $j^{\text{th}}$  GSP,  $v_j^{(s)}$  is the computational speed of resource and is expressed in terms of millions of instructions in one second (MIPS) and  $s_j^{(s)}$  denotes the attribute of storage capacity of the grid resource.

**Grid Market Auctioneer (GMA):** GMA is the auctioneer of the double auction. The job of GMA is to use the double auction protocol to control the behavior of auction market and decide the final winners of the auction.

In this paper a comprehensive index of QoS, i.e., the satisfaction degree is introduced into the double auction model. For the given GSP  $j$ 's multi-attribute, the GMA calculates the utility denoted by  $U_j^{(s)}$  according to the following satisfaction degree.

$$U_j^{(s)} = w_1 \frac{RP_i^{(b)} - bid_j^{(s)}}{RP_i^{(b)}} + w_2 \frac{T_i^{(b)} - \frac{L_i^{(b)}}{v_j^{(s)}}}{T_i^{(b)}} + w_3 \frac{s_j^{(s)} - S_i^{(b)}}{s_j^{(s)}} \quad (1)$$

where  $0 \leq w_1 \leq 1, 0 \leq w_2 \leq 1$  and  $0 \leq w_3 \leq 1$  indicate the weights of computational speed, price and memory size, respectively. It is clear that  $w_1 + w_2 + w_3 = 1$ .

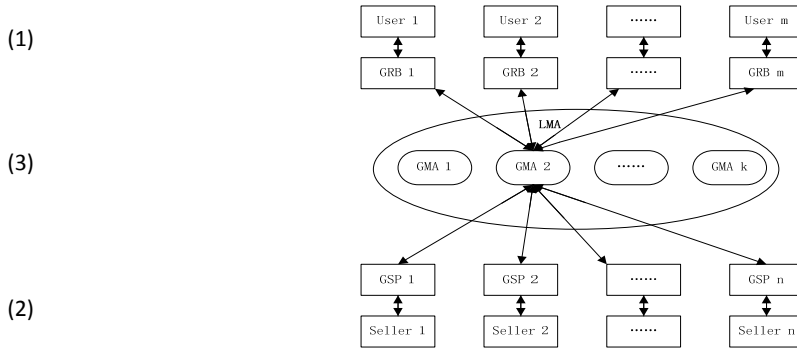

**Figure 1.** Overview of the architecture: the resource users use the GRBs to create a valid schedule (1). Resource providers use GSPs in order to connect their local scheduling systems to the GMAs (2). The GRBs and GSPs interact to maximize the utilities of their owners in the Local Market for Auctions (LMA) (3).

**3. Multi-Attribute Double Auction Models and Protocols**

We assume that there are  $m$  GRBs (buyers) and  $n$  GSPs (sellers) to participate in double auction. After GRBs and GSPs send the information of their prices to GMA within the limited time, GMA collects and sorts all bidding and asking prices. Generally, the bidding price and asking price sequences satisfy that  $bid_1^{(s)} \leq bid_2^{(s)} \leq \dots \leq bid_n^{(s)}$  and  $a_1^{(b)} \geq a_2^{(b)} \geq \dots \geq a_m^{(b)}$ , respectively. I.e., the demand prices are decreasing and the supply prices are increasing. We describe these characters in Fig.2, in which the horizontal axis denotes the quantity  $q$  and the vertical axis denotes the price  $p$  of grid resource. The

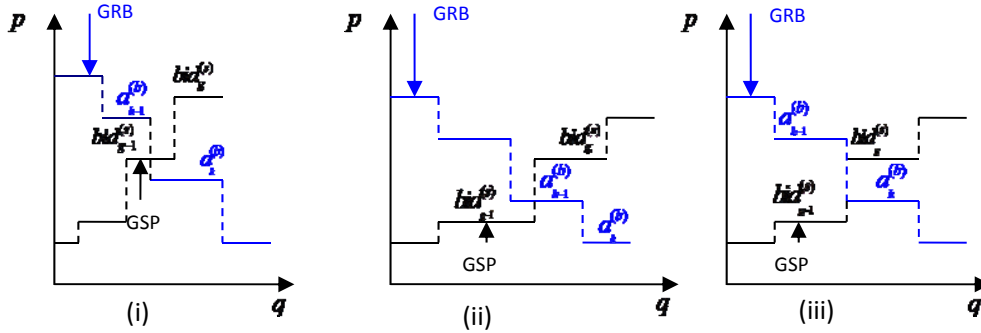

**Figure 2.** Illustration of matching

point where these two curves intersect is the equilibrium price, i.e., the  $(g - 1)^{th}$  GSP's bidding price  $bid_{g-1}^{(s)}$  is the final trading price or temporary winning price (see details in the following subsections).

In Fig.2, there are three cases about the equilibrium price, i.e., (i)  $a_k^{(b)} \leq bid_{g-1}^{(s)} \leq a_{k-1}^{(b)}$ , (ii)  $bid_{g-1}^{(s)} \leq a_{k-1}^{(b)} \leq bid_g^{(s)}$ , (iii)  $bid_{g-1}^{(s)} \leq a_{k-1}^{(b)}$  and  $a_k^{(b)} \leq bid_g^{(s)}$ . Considering fairness, the GSPs before  $(g - 1)$  all become the final or temporary winners and the GRBs before  $(k - 1)$  all become the final winners in the double auction. We assume the trading price of the double auction is  $p$  and the final transaction quantities of each GRB and GSP are  $Q_i^{(b)}$  and  $Q_j^{(s)}$ , respectively.

In the following subsections, we describe the Single Price Double Auction protocol (SPDA), in which the winners are decided only depending on the price-attribute and the Multiple Attribute Double Auction protocol (MADA), in which multiple attributes are deciding factors.

### 3.1. SPDA protocol

Step1: GRBs and GSPs send the information of their prices and quantities to GMA within the limited time.

Step2: GMA accepts and sorts the bidding prices and the asking prices. According to rules about the equilibrium price in Fig.2, GMA determines the final winners of GRB and GSP in the double auction.

Step3: The final trading price is calculated by the following equation.

$$p = \frac{bid_{g-1}^{(s)} + a_{k-1}^{(b)}}{2}$$

The trading quantities are allocated by the following rules.

Case 1: If the demand and supply quantities of GRBs and GSPs satisfy  $\sum_{j=1}^{g-1} q_j^{(s)} \leq \sum_{i=1}^{k-1} q_i^{(b)}$ , it means that demand exceeds supply. Therefore, the trading quantities of  $j^{th}$  winning GSP is  $Q_j^{(s)} = q_j^{(s)}$  and the trading quantities of  $i^{th}$  winning GRB is

$$Q_i^{(b)} = q_i^{(b)} \left( \frac{\sum_{j=1}^{g-1} q_j^{(s)}}{\sum_{i=1}^{k-1} q_i^{(b)}} \right).$$

Case 2: If the demand and supply quantities of GRBs and GSPs satisfy  $\sum_{j=1}^{g-1} q_j^{(s)} > \sum_{i=1}^{k-1} q_i^{(b)}$ , the supply exceeds demand. Therefore, the trading quantities of  $j^{th}$  winning GSP is  $Q_j^{(s)} = q_j^{(s)} \left( \frac{\sum_{i=1}^{k-1} q_i^{(b)}}{\sum_{j=1}^{g-1} q_j^{(s)}} \right)$ .

The trading quantities of  $i^{th}$  winning GRB is  $Q_i^{(b)} = q_i^{(b)}$ .

Step 4: GMA informs each GRB and GSP the results of the double auction, e.g., winner or loser, trading price and quantities.

Step5: The winning GSPs provides grid resources to the winning GRBs, and GRBs pay for its service.

### 3.2. MADA protocol

Different from the SPDA protocol, we present novel rules about the final winners based on the request of satisfaction degree about QoS of computational grid resource providers. Let  $\Gamma$  and  $F$  denote the sets of temporary and final winning GSPs, respectively. Suppose that  $K$  is the set of the final winning GRBs. The MADA protocol is as follows.

Step1: GRBs and GSPs send the information of their prices, quantities and other required attributes, e.g., speed, time and memory size to GMA within the limited time.

Step2: GMA accepts and sorts the bidding prices and the asking prices. The final winning GRBs and the temporary winners of GSPs are made sure based on the equilibrium price rules in Fig.2.

Step3: GMA determines the final winners among the temporary winners of GSPs according to the comprehensive utility computed by satisfaction degree.

The final trading price is calculated by comparing the  $(g-1)^{th}$  GSP's utility with the  $g^{th}$  GSP's utility, that is

$$p = \left\{ bid_j^{(s)} \mid \max(U_{g-1}^{(s)}(bid_j^{(s)}), U_g^{(s)}(bid_j^{(s)})) \right\}$$

Furthermore, if the utility of each temporary winning GSP satisfies  $U_j^{(s)} \geq \max\{U_{g-1}^{(s)}, U_g^{(s)}\}$ , the temporary winning GSPs become the final winner, else they become the losers.

Step4: GMA allocates the trading quantities for both winning GRBs and GSPs by the following rules.

Case 1: When the demand exceeds supply, i.e.,  $\sum_{j \in F} q_j^{(s)} - \sum_{j \in \Gamma} q_j^{(s)} \leq \sum_{i \in K} q_i^{(b)}$ , the trading quantities of  $j^{\text{th}}$  winning GSP is  $Q_j^{(s)} = q_j^{(s)}$  and the trading quantities of  $i^{\text{th}}$  winning GRB is  $Q_i^{(b)} = q_i^{(b)} \left\{ \left( \sum_{j \in F} q_j^{(s)} - \sum_{j \in \Gamma} q_j^{(s)} \right) / \sum_{i \in K} q_i^{(b)} \right\}$ .

Case 2: When the supply exceeds demand, i.e.,  $\sum_{j \in F} q_j^{(s)} - \sum_{j \in \Gamma} q_j^{(s)} > \sum_{i \in K} q_i^{(b)}$ , the trading quantities of  $j^{\text{th}}$  winning GSP is  $Q_j^{(s)} = q_j^{(s)} \left\{ \sum_{i \in K} q_i^{(b)} / \left( \sum_{j \in F} q_j^{(s)} - \sum_{j \in \Gamma} q_j^{(s)} \right) \right\}$  and the trading quantities of  $i^{\text{th}}$  winning GRB is  $Q_i^{(b)} = q_i^{(b)}$ .

Step5: GMA informs each GRB and GSP the result of the double auction.

Step6: The winning GSPs provide grid resources to GRBs, and GRBs pay for their services.

#### 4. Simulation and Experimental Results

In this section the simulations are given to describe the SPDA protocol and MADA protocol. In our simulation, we assume the grid resource is PC. I.e., there are 20 grid PC buyers and 30 PC sellers, the length of the jobs are considered as a random integer within the range [5000, 15000] MZ sampled from a uniform distribution. Also the computational capacity of GRB's request and GSP is normally distributed within the range [100,500] MZ/s, storage capacity distributed within [1,8] G. The price that resource provider can be accepted over [50,250] G\$/MIPS, the price that resource buyer can offer distributed over [100,200] G\$/MIPS. The quantities that GSPs can provide and GRBs required are both within the range of [10,20]. The utility of each GSP's asking bid is set according to Eq.1. Also in our experiments, we assume that  $w_1=0.3$ ,  $w_2=0.4$  and  $w_3=0.3$ .

We simulate the process of the multi-attribute double auction, in which each point has two axes,  $x$  label denotes the total quantities that GRBs required or GSPs can provide and  $y$  label denotes the prices that GRBs bidding and GSPs asking to the GMA. From Fig.3, we can know that the bidding price of the 12<sup>th</sup> GRB is between the asking price of the 14<sup>th</sup> and 15<sup>th</sup> GSP, belongs to the second situation as mentioned in Fig.2. Then we compare the utility of the 14<sup>th</sup> and the 15<sup>th</sup> GSP, i.e.,  $U_{14}^{(s)} > U_{15}^{(s)}$ . The result is that the asking price of the 14<sup>th</sup> GSP is the unite price of the double auction.

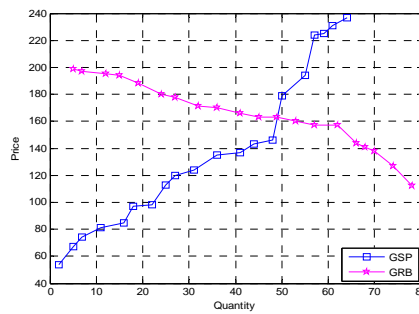

Figure 3. The process of sort on price

The GRBs and GSPs before the intersection compose the sets of temporary winners of the double auction. In Fig.4, we choose the final winners of the multi-attribute double auction based on the utility of

$U_{14}^{(s)}$ . As shown in Fig.4, the black line denotes the value of  $U_{14}^{(s)}$ , the GSPs whose utilities are larger than  $U_{14}^{(s)}$  become the final winners, i.e., the winners are from 1 to 6.

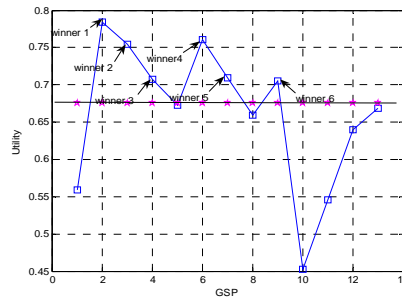

Figure 4. Diagram of winners

According to the equation mentioned before, we simulate the trading quantities of GRBs and GSPs in Fig.5. For simplicity, we only describe such case that the supply exceeds demand.

In Fig.6, this paper compares the average utilities of the SPDA protocol and MADA protocol. As Fig.6 shows that the average utilities of MADA protocol is higher than that of SPDA protocol. This highlights that fairness and satisfaction degree can help GRBs choose final winners in the double auction models and achieve more effective in improving the buyer’s utility.

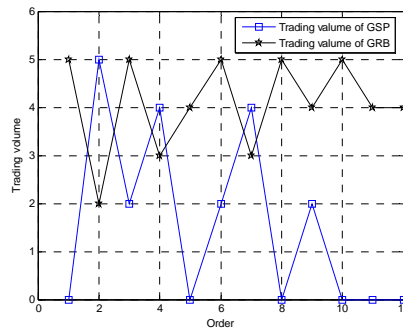

Figure 5. Trading quantities of GRBs and GSPs

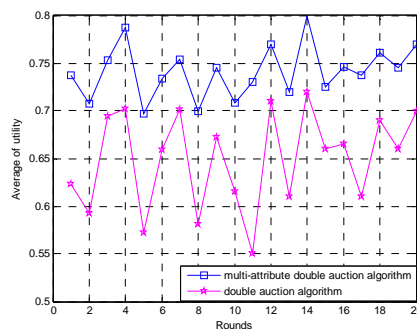

Figure 6. Comparison of average utilities

### 5. Conclusions

In this paper, we propose an improved double auction model. Firstly, we investigate multi-attribute characteristics of grid resource in the double auction models and present two protocols to describe the

matching processes based on double auction. The simulations show that the method this paper proposed is much more efficient than the previous methods in satisfying the utility of the grid resource buyers. The experimental results clearly illustrate that the proposed method is efficient and can be used for solving such problems.

### References

- [1] Attanasio, Andrea, et al. "Auction algorithms for decentralized parallel machine scheduling." *Parallel Computing* 32.9 (2006): 701-709.
- [2] Izakian, Hesam, Ajith Abraham, and Behrouz Tork Ladani. "An auction method for resource allocation in computational grids." *Future Generation Computer Systems* 26.2 (2010): 228-235
- [3] Haque, Aminul, Saadat M. Alhashmi, and Rajendran Parthiban. "Towards better understanding of two economic models: a grid perspective." *Communications of the IBIMA 2011* (2011).
- [4] Buyya, Rajkumar, et al. "Economic models for resource management and scheduling in grid computing." *Concurrency and computation: practice and experience* 14.13 - 15 (2002): 1507-1542.
- [5] Suri, P. K., and Manpreet Singh. "Auction oriented resource allocation in grid using knowledge based pricing policy." *IJCSNS* 9.9 (2009): 91.
- [6] Das, Anubhav, and Daniel Grosu. "Combinatorial auction-based protocols for resource allocation in grids." *Parallel and Distributed Processing Symposium, 2005. Proceedings. 19th IEEE International. IEEE, 2005.*
- [7] Lavi, Ron, Ahuva Mu'Alem, and Noam Nisan. "Towards a characterization of truthful combinatorial auctions." *Foundations of Computer Science, 2003. Proceedings. 44th Annual IEEE Symposium on. IEEE, 2003.*
- [8] D. Fang, X. Wang, Y. Zhang, K. Liu, P. Wang. "Double auction bayesian model with supplier and demander in open bilateral electricity market". *Power System Technology*. 2003, 27(12): 1-5.
- [9] Prodan, Radu, Marek Wieczorek, and Hamid Mohammadi Fard. "Double auction-based scheduling of scientific applications in distributed grid and cloud environments." *Journal of Grid Computing* 9.4 (2011): 531-548.
- [10] Kant, Umesh, and Daniel Grosu. "Double Auction Protocols for Resource Allocation in Grids." *ITCC* (1). 2005.
- [11] Buyya, Rajkumar, et al. "Economic models for management of resources in peer-to-peer and grid computing." *ITCom 2001: International Symposium on the Convergence of IT and Communications. International Society for Optics and Photonics, 2001.*